



Power-Over-Ethernet Weatherproof 18" x 16" x 8" Enclosure with Equipment Mounting Plate and Cooling Fans

Applications and Features

Applications:

- Remote Wireless LAN WiFi equipment installations using Power-Over-Ethernet
- Indoor and outdoor installations
- Hot temperature environments
- Installations requiring dual access points
- Corrosive environments
- Hotspot applications
- Protection of equipment from theft or damage

Features:

- Molded fiberglass reinforced polyester enclosure
- Large size is ideal for applications requiring more than one radio
- Stainless steel quick release latches with padlock hasps
- Fully gasketed lid and Integral mounting flange
- NEMA Type 3R / IP42 rated
- Aluminum mounting plate with Power-Over-Ethernet interface and lightning protection
- Thermostat-controlled cooling fans
- Mounting plate can accommodate WLAN equipment from Cisco®, Symbol®, D-Link®, HyperLink and more..
- Optional universal equipment shelf and mounting brackets available

Model: NB181608-40F



NB181608-40F

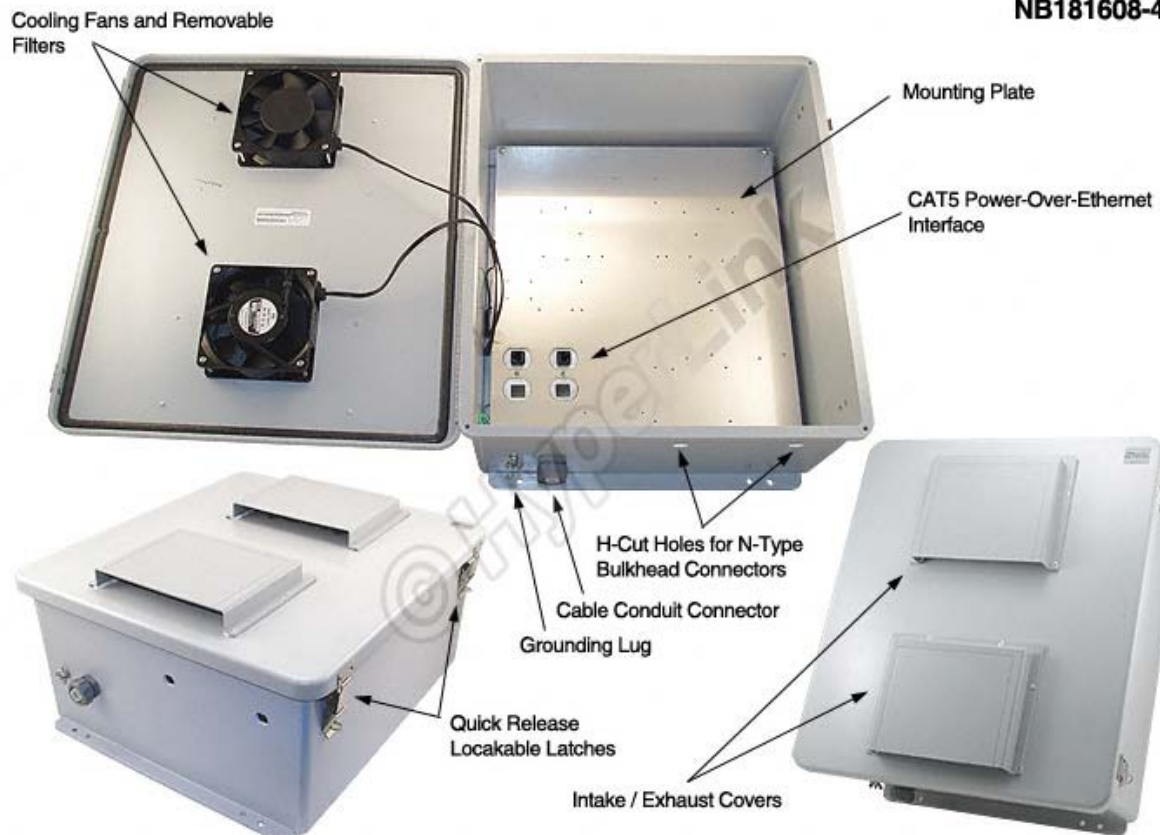

Model: NB181608-40F

Product Description

Start with the Box...

The box is a rugged 18" x 16" x 8" weatherproof enclosure that is ideal for both indoor and outdoor applications. Constructed from molded fiberglass, it is well suited for high temperature or corrosive environments. The mounting flange allows it to be wall mounted as well as on a flat surface. The box can also be pole mounted with the optional pole mounting hardware kit. The fully gasketed lid features a stainless steel continuous hinge and stainless steel quick release latches with padlock hasps. The enclosure material is UV stabilized and comes in machine tool gray. The enclosure also features holes for mounting Lightning Protectors or Connectors, a grounding lug and ½" cable conduit connector.



Due to the large size of this enclosure, it can accommodate dual sets of most access points. The example to the right shows one of the many ways the enclosure can be configured.

Mounting Plate

The aluminum mounting plate has provisions to mount WLAN equipment from Cisco®, Symbol®, D-Link®, HyperLink and more (see mounting plate drawing). With the optional HGX-AMOUNT02 bracket a wide array of HyperLink Amplifiers, Power-Over-Ethernet products and Power Supplies can be mounted as well. Two of these brackets can be mounted side by side. Also available is the HGX-NMOUNT03 Universal Mounting Shelf that can be attached to the mounting plate and can accommodate additional equipment to be placed in the enclosure.

Power-Over-Ethernet (PoE)

The Mounting Plate features a CAT5 PoE interface that is used to split the Data and Power carried by a CAT5 cable to the internal equipment and supply 48 volts DC to the cooling Fan. The interface includes Lightning Protection and support for normal and reverse polarity POE equipment. To supply the required current to the equipment and Fan, the HyperLink BT-CAT5-P1-4840 power supply and injector kit should be used. Cisco® PoE equipment requires substitution of a BT-CAT5-P1R4840 kit to supply reverse polarity 48 volts. An optional PoE interface surge protector can be added to add protection for a second CAT5 cable.

Cooling Fans

The NB181608-40F model includes thermostat controlled 48 VDC Cooling Fans that are powered via the CAT5 PoE interface. The high airflow, low noise fans used allows air to be pushed or pulled through the enclosure. Filters for both ports are easily removable for cleaning and replacement. The fans turn on when the internal temperature rises to 120° F (49° C) and turns off at 90° F (32° C).

Lightning Protection

The PoE interface features built in lightning protection. This helps add an extra level of protection to PoE equipment installed in the enclosure. In addition, the unit can accept up to two optional bulkhead-mount N-Type lightning protectors to protect the coaxial cable runs. An additional PoE interface is available for use in the enclosure (see accessories below).

Specifications

Models	NB181608-40F
Mounting Plate Material	.10" (2.5mm) Thick Anodized Aluminum
Mounting Plate Dimensions	16.8 x 14.8 inches (42.6 x 37.5 cm)
Enclosure Material	UV-inhibited Fiberglass
Enclosure Color	Machine Tool Gray
Weight	20.3 lbs (9.2 kg)
Outside Dimensions (max)	19.5 x 17.5 x 10 inches (49.5 x 44.4 x 25.4 cm)
Inside Dimensions	17.7 x 15.7 x 8.5 inches (44.9 x 39.9 x 21.6 cm)
Flame Rating	UL 94-5V
Cable Feed	1/2" Cable Conduit Connector
Ratings	NEMA 3R / IP42

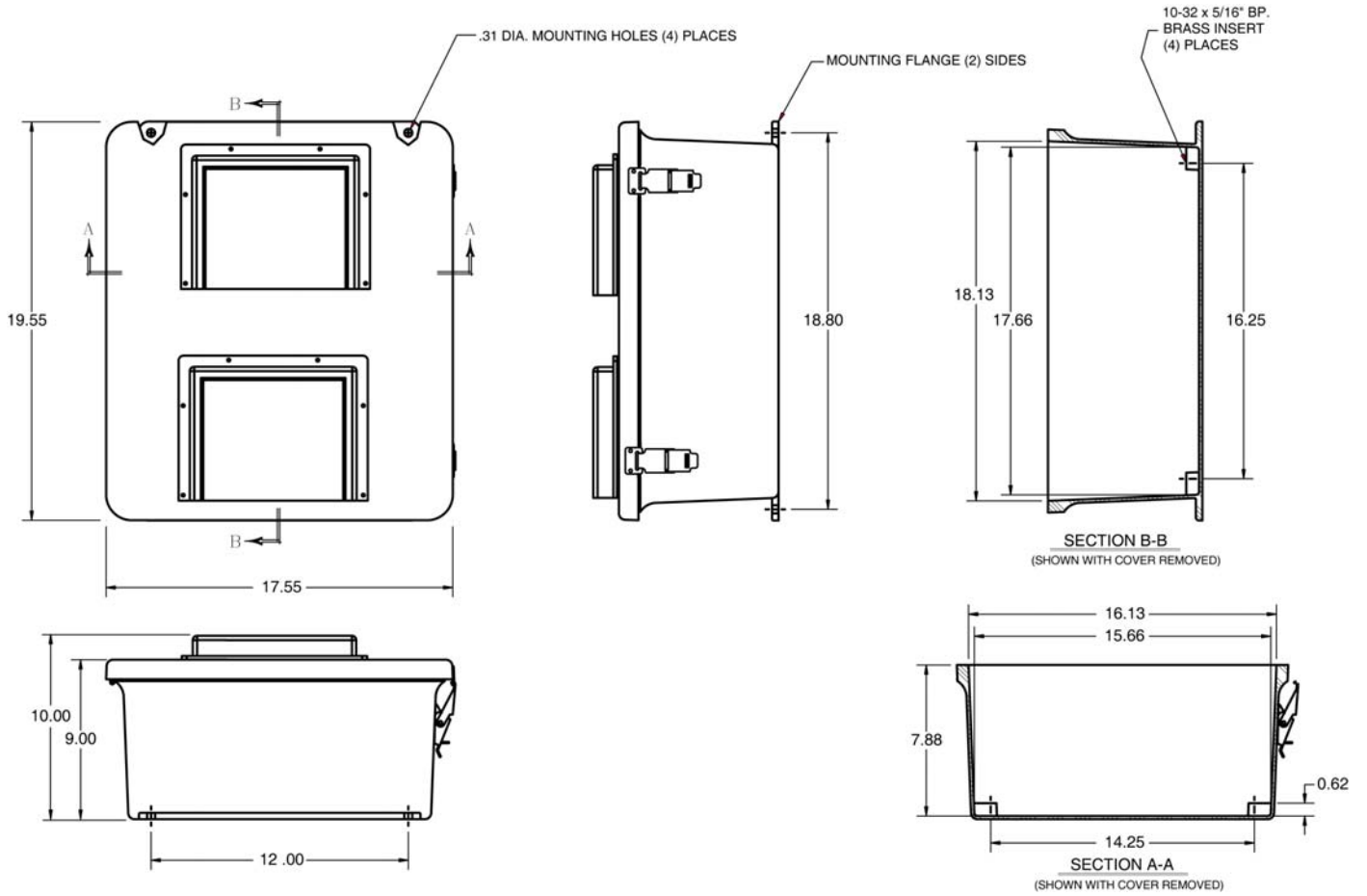

Model: NB181608-40F

Enclosure Dimensions



Model: NB181608-40F



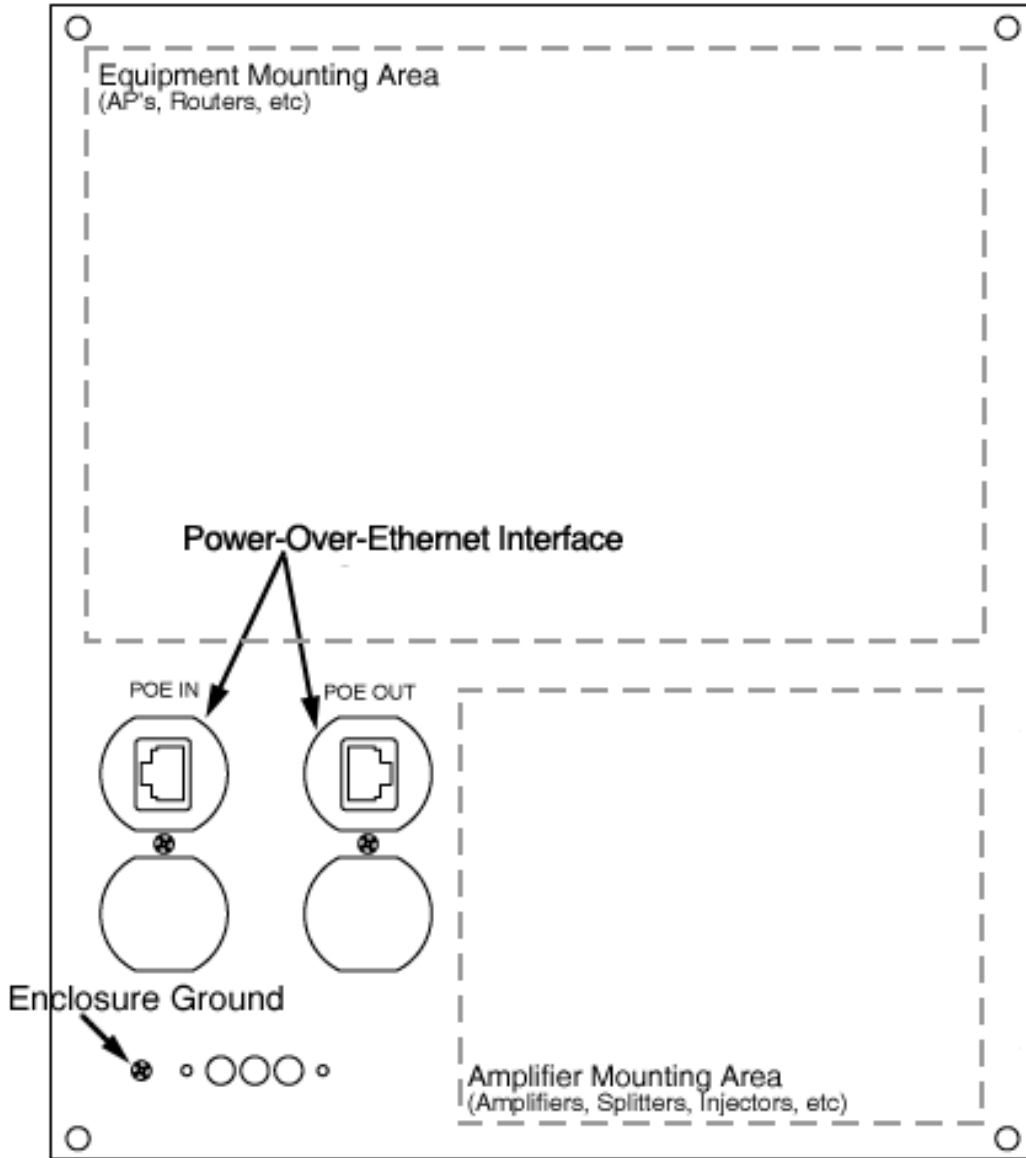









Mounting Plate Details











Model: NB181608-40F

Enclosure Accessories

Mounting Brackets	
Part Number	Description
 HGX-PMT13	Universal Pole Mounting Kit. This kit is used to mount NB141207 or NB181608 series weatherproof enclosure to 2" (50.8mm) to 4" (101.6mm) Dia. Poles. For larger diameter poles, slots are provided in the rails for 1/2" (12.7mm) wide worm drive clamps. Kit includes: (2) Mounting Rails and (2) U-Bolts and Hardware For poles 1-1/4" (31.7mm) to (50.8mm) dia. the HGX-PMT07 (2 required) can be used with this kit.
 HGX-PMT07	U-Bolt Kit for mounting to 1-1/4" (31.7mm) to (50.8mm) dia. poles. For use with the HGX-PMT13. Kit includes (1) zinc plated steel U-Bolt and hardware.
 XMH-0007	Mounting Plate Standoff, for use in the NB181608 NEMA enclosure. Standoff is 1" (25mm) tall with 10-32 tapped hole.
 HGX-NMOUNT03	Universal Equipment Shelf. Mounts to pre-drilled NEMA plate. Includes (2) #6 Screws for securing shelf to mounting plate. Ideal for mounting free standing equipment such as Buffalo AirStations®, Cisco Aironet® 1100 Access Points, D-Link® and Linksys® wireless products as well as others. Shelf dimensions: 7.5" Wide x 2.9" Deep (190.5 mm x 73.6 mm)
 HGX-NMOUNT04	Mounting Bracket Kit for use with dual Cisco Aironet® 1200 APs. This bracket enables two 1200 APs to be mounted in the enclosure. Includes mounting hardware.
 HGX-AMOUNT02	Mounting bracket for HyperLink Amplifiers, PoE Products and Power Supplies. Mounts to pre-drilled NEMA plate. Hardware included.
 HGX-NMOUNT02	Mounting bracket for Nortel Networks® 2230 / Airespace® 1200 Access Points. Mounts to pre-drilled NEMA plate. Hardware included.
DC Jumper Cables	
 CA-21R21RK002	DC Jumper Cable: 2ft, 2.1mm to 2.1mm
 CA-21R25RK002	DC Jumper Cable: 2ft, 2.1mm to 2.5mm
 CA-25R25RK002	DC Jumper Cable: 2ft, 2.5mm to 2.5mm
 CA-21K006	DC Jumper Cable: 6ft, 2.1mm to tinned end leads
 CA-25K006	DC Jumper Cable: 6ft, 2.5mm to tinned end leads



Model: NB181608-40F

Accessories	
Part Number	Description
 BT-CAT5-P1R4840	HyperLink Reverse Polarity Single-Port Passive Injector Kit This Power-over-Ethernet injector is compatible with Cisco Aironet® 1100 and 1200 Series Access Points and other equipment supporting reverse polarity PoE pinouts. Kit includes Injector (BT-CAT5-P1R) and 48 VDC @ 40W power supply.
 BT-CAT5-P1-4840	HyperLink Single-Port 48V Power-over-Ethernet Kit Kit includes PoE Passive Injector (BT-CAT5-P1) and 48 VDC @ 40W power supply.
 ASR-PG13	PG-13.5 Liquid-Tight Cable Conduit Connector. For use with HyperLink weatherproof enclosures, this liquid-tight cable conduit connector features neoprene seals, nylon construction and can accommodate cord dia. sizes from 0.236" to 0.472". This is a direct replacement for the existing cable conduit connector.
 ASR-PG16	PG-16 Liquid-Tight Cable Conduit Connector. This liquid-tight cable conduit connector features neoprene seals, nylon construction and can accommodate cord dia. sizes from 0.394" to 0.551". The ASR-PG16 will pass a RJ45 connector.
 H-PCB-5148	Designed for use with HyperLink's HIC-4xx series Power-Over-Ethernet (PoE) Enclosures, this PoE Passive Interface Board provides an additional CAT5 interface with lightning protection. Attaches directly to existing aluminum mounting plate.
 XMH-0023	Single Surface Mount CAT5 Jack Housing (TAN)
 XMH-0024	Unshielded CAT5 Punch Down Jack For use with XMH-0023 Housing



Model: NB181608-40F

Additional Enclosure Models

Enclosure Sizes:

12" x 10" x 5" (30.4 x 25.4 x 12.7 cm), Part Number **NB121005-xxx**

14" x 12" x 7" (35.5 x 30.4 x 17.7 cm), Part Number **NB141207-xxx**

18" x 16" x 8" (45.7 x 40.6 x 20.3 cm), Part Number **NB181608-xxx**

Model Options	Enclosure with	Vented Enclosure with	Enclosure with Heat	Enclosure with Cooling Fan	Enclosure with Cooling Fan & Heat
110 VAC	NB141207-100 NBP141004-100 NB181608-400	-	NB141207-1H0 NB181608-1H0	NB141207-10F NB181608-40F	NB141207-1HF NB181608-1HF
Power-Over-Ethernet	NB141207-400 NB181608-400	NB181608-40V	-	NB141207-40F NB181608-40F	-
220 VAC	NB141207-200 NB181608-200	NB181608-20V	NB141207-2H0 NB181608-2H0	NB141207-20F NB181608-20F	NB141207-2HF NB181608-2HF
220 VAC (European)	NB141207-E00 NB181608-E00	NB181608-E0V	NB141207-EH0 NB181608-EH0	NB141207-E0F NB181608-E0F	NB141207-EHF NB181608-EHF
12 VDC	NB141207-500 NB181608-500	NB181608-50V	-	NB141207-50F NB181608-50F	NB181608-5SF
Sub-Zero Applications	-	-	NB141207-4H0	-	-
No Mounting Plate	NB141207 NB121005 NB181608	-	-	-	-
Mounting Plate	NB141207-01 NB121005-01 NB181608-01	NB141207-00V NB181608-00V	-	-	-